

# HYDROFRESH-24CL

**Small pressure sets with 20 litre cylindrical vessel, for automatic operation. Suitable for the supply of pressurised water in the home or in holiday homes.**



## PERFORMANCE AND DIMENSIONS

TYPE	PORTS		POWER		FLOW RATE (1) l/min	SETTING (recommended) (2)		DIMENSIONS		
	suc.	deliv.	kW	HP		min	max	l	a	h
Single-phase										
PKm 60 - 24 CL	1"	1"	0.37	0.50	32	1.4	2.8	540	255	475
PKm 65 - 24 CL	1"	1"	0.50	0.70	40	1.5	3.0	540	255	480
PKm 70 - 24 CL	1"	1"	0.60	0.85	50	1.8	3.2	540	255	490
PKm 80 - 24 CL	1"	1"	0.75	1	50	2.2	3.6	540	255	490
PKm 100 - 24 CL	1"	1"	1.1	1.5	50	3.5	4.5	540	255	510
PKSm 60 - 24 CL	1"	1"	0.37	0.50	32	1.4	2.8	540	255	540
PKSm 65 - 24 CL	1"	1"	0.50	0.70	40	1.5	3.0	540	255	540
PKSm 70 - 24 CL	1"	1"	0.60	0.85	50	1.8	3.2	540	255	550
PKSm 80 - 24 CL	1"	1"	0.75	1	50	2.2	3.6	540	255	550
CPm 152 - 24 CL	1"	1"	0.55	0.75	80	1.4	2.8	540	255	580
CPm 158 - 24 CL	1"	1"	0.75	1	90	1.8	3.2	540	255	580
CPm 170 - 24 CL	1 1/4"	1"	1.1	1.5	120	2.2	3.5	540	255	595
CPm 170M-24 CL	1 1/4"	1"	1.1	1.5	150	2.0	3.5	540	255	595
2CPm 25/130N - 24 CL	1 1/4"	1"	0.75	1	100	1.4	2.8	540	255	538
2CPm 25/140H - 24 CL	1 1/4"	1"	1.1	1.5	100	2.2	3.6	540	255	562
2CPm 25/140M - 24 CL	1 1/2"	1"	1.1	1.5	140	2.2	3.6	540	255	562
3CPm 80E - 24 CL	1"	1"	0.45	0.60	60	1.4	2.8	540	255	510
4CPm 80E - 24 CL	1"	1"	0.60	0.85	60	2.2	3.6	540	255	510
3CPm 100E - 24 CL	1"	1"	0.60	0.85	100	1.4	2.8	540	255	510
4CPm 100E - 24 CL	1"	1"	0.75	1	100	2	3.5	540	255	510
3CRm 80 - 24 CL	1"	1"	0.45	0.60	60	1.4	2.8	540	255	509
4CRm 80 - 24 CL	1"	1"	0.60	0.85	60	2.2	3.6	540	255	509
3CRm 100 - 24 CL	1"	1"	0.60	0.85	100	1.4	2.8	540	255	509
JSWm 1C - 24 CL	1"	1"	0.37	0.50	45	1.2	2.6	540	265	497
JSWm 1B - 24 CL	1"	1"	0.50	0.70	50	1.4	2.8	540	265	497
JSWm 1A - 24 CL	1"	1"	0.60	0.85	50	1.8	3.2	540	265	497
JSWm 10H - 24 CL	1"	1"	0.75	1	50	2.0	3.2	540	315	515
JSWm 12H - 24 CL	1"	1"	0.90	1.25	50	2.5	4.0	540	315	515
JSWm 15H - 24 CL	1"	1"	1.1	1.5	50	3.0	4.5	540	315	515
JSWm 10M - 24 CL	1"	1"	0.75	1	80	1.4	2.8	540	315	515
JSWm 12M - 24 CL	1"	1"	0.90	1.25	80	2.0	3.5	540	315	515
JSWm 15M - 24 CL	1"	1"	1.1	1.5	80	2.5	4.0	540	315	515
JSWm 3CH - 24 CL	1 1/4"	1"	1.1	1.5	70	3.0	4.5	540	290	545
JSWm 3CM - 24 CL	1 1/4"	1"	1.1	1.5	120	2.0	3.5	540	290	545
JSWm 3CL - 24 CL	1 1/4"	1"	1.1	1.5	160	1.4	2.8	540	290	545
JCRm 1C - 24 CL	1"	1"	0.37	0.50	50	1.2	2.6	540	255	509
JCRm 1B - 24 CL	1"	1"	0.50	0.70	50	1.4	2.8	540	255	509
JCRm 1A - 24 CL	1"	1"	0.60	0.85	50	1.8	3.2	540	255	509
JCRm 10H - 24 CL	1 1/4"	1"	0.75	1	50	2.0	3.4	540	255	539
JCRm 12H - 24 CL	1 1/4"	1"	0.90	1.25	50	2.4	3.8	540	255	539
JCRm 15H - 24 CL	1 1/4"	1"	1.1	1.5	50	3.0	4.0	540	255	539
JCRm 10M - 24 CL	1 1/4"	1"	0.75	1	80	1.4	2.8	540	255	539
JCRm 12M - 24 CL	1 1/4"	1"	0.90	1.25	80	2.0	3.5	540	255	539
JCRm 15M - 24 CL	1 1/4"	1"	1.1	1.5	80	2.5	4.0	540	255	539

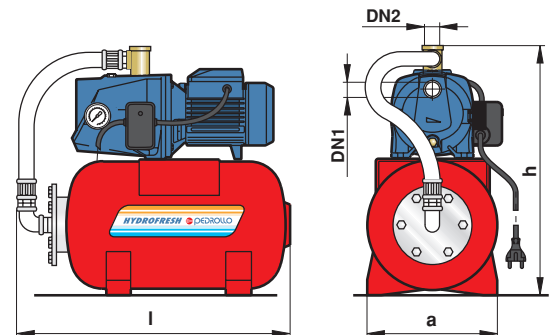

### HYDROFRESH 24 CL COMPONENTS

- Single-phase pump
- 20 litre cylindrical vessel
- Hose
- Pressure switch "SQUARE-D"
- Pressure gauge
- 3 or 5-way brass connector
- 1.5 metre cable with Schuko plug

- (1) Maximum flow rate with the minimum recommended pressure switch setting  
 (2) Pressure switch recommended rate

N.B. The pre-charge of air in diaphragm tanks must be set to a value 0.2 bar lower than the minimum setting of the pressure switch.